

BAKER ATTITUDE CHAIN ADJUSTER

PN 177-67K

INSTALLATION INSTRUCTIONS

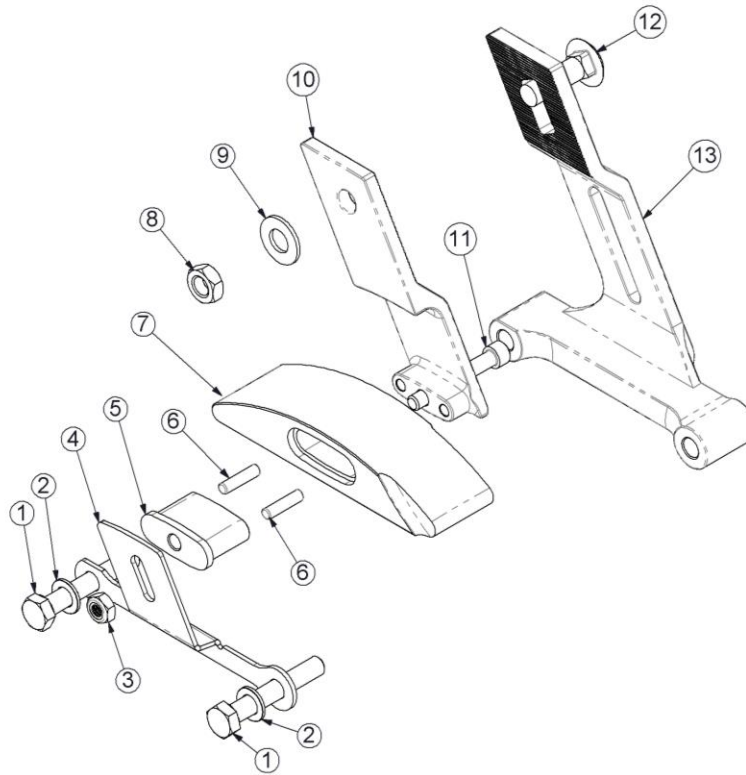

TAG	PN	QTY	DESCRIPTION
1	13061	2	5/16-18 X 2", Hex Bolt, Zinc
2	6100	2	5/16" ID AN Washers, SS
3	25CNTE8Y	1	1/4-20 Low Head Nylock Nut
4	178-67	1	Support Plate, 14 Gauge
5	177-67	1	Keeper, Shoe
6	26738	2	3/16" x 3/4" Hardened Dowel
7	176-67	1	Shoe
8	37024	1	3/8-16 Nylock Nut
9	33082	1	3/8" ID SAE Washer
10	175-67	1	Active Plate
11	25C175KCS	1	1/4-20 x 1.75", SHCS, Black Oxide
12	21818	1	3/8-16 x 1.25" Carriage Bolt, Zinc
13	174-67	1	Backing Plate

FEATURES

The Attitude Chain Adjuster solves the issues associated with the stock auto chain tensioner on 2006-Later Dyna & 2007-Later Softail/ Touring models. The first moment the chain has enough slack into it to ratchet the shoe up another notch, and thus tightening the chain, it will. One notch tighter might not be an issue, but you don't have any control of when this mechanism stops tightening the chain. The end result in many cases is the primary chain is so tight that it will start wearing out left side motor case bearings, inner primary bearings, clutch hub bearings and transmission output gear bearings. Our manual chain tensioner allows you to adjust the chain to the proper 5/8-7/8" (cold) free play, and never have to worry about the chain getting too tight. We offer this chain adjuster for fitment with stock outer primary covers.

BAKER ATTITUDE CHAIN ADJUSTER

FITMENT

- 2006-Later Dyna®
- 2007-Later Softail®
- 2007-Later Touring

INSTALLATION

- 1) Disconnect the battery, drain the primary fluid, remove the spark plugs and safely support the motorcycle.
- 2) Remove the foot pegs or floorboards on the left side of the motorcycle and the outer primary cover.
- 3) Remove the motor sprocket nut and sprocket assembly with primary chain. Remove the stock auto tensioner assembly and set aside. Before proceeding check the threaded holes for mounting the tensioner, in the inner primary, are free of thread lock, oil and debris.
- 4) Slide the BAKER Attitude Chain Adjuster into the primary, without the outer support using the provided 5/16-18 x 2" Hex Head bolts. Just snug the bolts for now for installation of chain and sprockets.
- 5) Install the compensator sprocket assembly with primary chain and bolt per the factory service manual for your model.
- 6) Remove the provided 5/16-18 x 2" bolts used to retain the Attitude Adjuster. Install the support plate PN 178-67; referencing the exploded view. Reinstall using blue thread lock the provided 5/16-18 x 2" hex head bolts with washers, torque the hex bolts to 220 in-lbs.
- 7) The Attitude Adjuster functions in the same manner as a 2001-06 stock style 'L-Bracket' Chain tensioner. Adjust the chain to 5/8"-7/8" upward free play if the motorcycle is cold, or 3/8"-5/8" upward free play if the bike is hot. Check the free play at multiple points in the chain by turning over the clutch and compensator sprocket to find the tight and loose spots inherent in every primary chain. Set the adjuster at the tightest spot on the chain (within 5/8"-7/8"). Tighten the 3/8" Nylock nut to 21-29 ft-lbs when satisfied with the adjustment.

DISCLAIMER:



IT IS HIGHLY IMPORTANT TO CHECK THE TENSION ON THE CHAIN AT MULTIPLE POINTS BEFORE RUNNING THE MOTORCYCLE. BAKER DRIVETRAIN WILL NOT BE HELD RESPONSIBLE AND THE ATTITUDE ADJUSTER WILL NO LONGER BE UNDER WARRANTY IF THE ADJUSTER BREAKS DUE TO INACCURATE CHAIN TENSION.

WHEN ADJUSTING THE CHAIN TENSIONER, BE SURE TO ROTATE THE SPROCKETS 360 DEGREES, CHECKING THE CHAIN SLACK IN MULTIPLE SPOTS. THE CHAIN WILL VARY IN THE AMOUNT OF SLACK ALL AROUND. FIND THE TIGHTEST SPOT IN THE CHAIN AND ADJUST THE TENSIONER ACCORDINGLY TO ALLOW AN AVERAGE AMOUNT OF SLACK OVER THE WHOLE CHAIN. 5/8"-7/8" WHEN CHAIN IS COLD OR 3/8"-5/8" WHEN CHAIN IS HOT.

IF THE CHAIN IS TOO TIGHT, THE ATTITUDE ADJUSTER WILL BEND IN A DOWNWARD MOTION CAUSING THE CHAIN TO WALK INWARD. THIS MOTION WILL WEAR THE TENSIONER SHOE AND THE ACTIVE PLATE ON THE ADJUSTER, WORST CAUSE, THE ADJUSTER MAY BREAK.

BAKER ATTITUDE CHAIN ADJUSTER

DISCLAIMER CONTINUED:



WHEN INSTALLING A NEW CHAIN, PLEASE BE SURE TO RECHECK AND ADJUST THE TENSIONER AFTER 150 MILES. NEW CHAINS AFTER 150 MILES WILL NEED TO BE RECHECKED FOR PROPER CHAIN TENSION/SLACK DUE TO THE CHAIN STRETCHING, BREAKING IN.

8) With the chain set at the proper tension, install the supplied 1/4-20 Low Head Nylock Nut to the support plate and torque the nut to 110 in-lbs.

9) Install the outer primary at this point per the factory service manual, replace the outer primary gasket at this time if appears to be kinked, bent or damaged in anyway.

10) Re-assemble the rest of the motorcycle, while referencing the service manual, fill the primary and head out on the road. **CHECK THE PRIMARY CHAIN ADJUSTMENT EVERY 5000 MILES.**

SOFTAIL AND DYNA



REMOVE THE DAMPENER BOLT FROM THE OUTER PRIMARY BEFORE RE-INSTALLING THE COVER. IT WILL INTERFERE WITH THE ATTITUDE ADJUSTER. SEE PICTURES BELOW OF THE DAMPENER BOLT AND IT'S LOCATION ON THE OUTER PRIMARY.

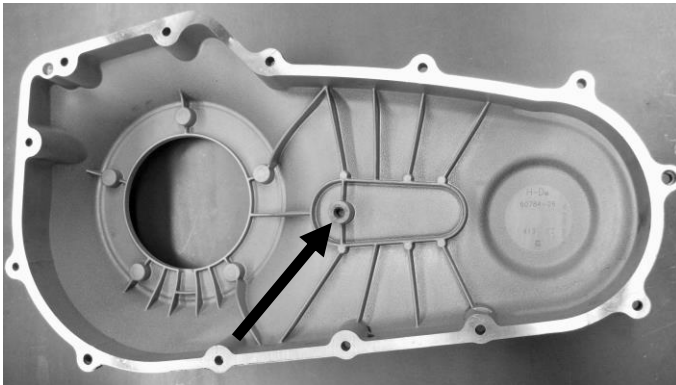

BAKER ATTITUDE CHAIN ADJUSTER

TERMS:

SPECIAL ORDERS

A minimum \$500 deposit is required with all special orders. Special orders include unique case finishes, unique side door requests (i.e.; wrinkle black door or no logo).

ALL OTHER ORDERS

Orders can be pre-paid using VISA, Mastercard or American Express.

Prices shown are F.O.B. Haslett, MI. UPS air shipment is available upon request. Customer is responsible for air shipment premiums.

LIMITED WARRANTY

BAKER™ transmission assemblies, transmission kits, primaries, and oil pans are guaranteed to the original purchaser to be free of manufacturing defects in materials and workmanship for a period of 5 years from the date of purchase or up to 50,000 miles – whichever occurs first. BAKER™ clutches, kicker cover kits, belt drives, F6F kit, reverse systems, covers and accessories are guaranteed to the original purchaser to be free of manufacturing defects in materials and workmanship for a period of 2 years from the date of purchase or up to 24,000 miles – whichever occurs first. If the product is found by BAKER™ to be defective, such products will, at the option of BAKER™, be replaced or repaired at cost to BAKER™

In the event warranty service is required, the original purchaser must call or write BAKER™ immediately with the problem. If it is deemed necessary for BAKER™ to make an evaluation to determine whether the transmission assembly or transmission kit is defective, the entire transmission assembly, whether originally purchased as an assembly or kit, must be properly packaged and returned prepaid to BAKER™ with a copy of the original invoice of purchase.

If after an evaluation has been made by BAKER™ and a defect in materials and/or workmanship is found, BAKER™ will, at BAKER™ option, repair or replace the defective part of the assembly.

Warranty card must be returned within 45 days of purchase to be valid.

ADDITIONAL WARRANTY PROVISIONS

This limited warranty does not cover labor or other costs or expenses incidental to the repair and or replacement of BAKER™ products. This warranty does not apply if one or more of the following situations is judged by BAKER™ to be relevant: improper installation, accident, modification (including but not limited to use of unauthorized parts), racing, high performance application, mishandling, misapplication, neglect (including but not limited to improper maintenance), or improper repair.

BAKER™ shall not be liable for any consequential or incidental damages arising out of or in connection with a BAKER™ transmission assembly, transmission kit, swingarm, fender, component or part. Consequential damages shall include without limitation, loss of use, income or profit, or losses sustained as the result of injury (including death) to any person or loss of or damage to property.

BAKER™ transmissions, transmission kits, and Wide Tire Kits are designed exclusively for use in Harley-Davidson® motorcycles. BAKER™ shall have no warranty or liability obligation if a BAKER™ part is used in any other application.

If it is determined that a BAKER™ transmission assembly has been disassembled during the warranty period for any reason, this limited warranty will no longer apply.

BAKER ATTITUDE CHAIN ADJUSTER

DISCLAIMER:

The words Harley, and H-D are registered trademarks and are for reference only. Use of H-D model designations and part numbers are for reference only. BAKER Drivetrain has no association with, and makes no claim against, these words, trademarks, or companies.

It is the sole responsibility of the user to determine the suitability of this product for his or her use, and the user shall assume all legal, personal injury risk and liability and all other as well as all other obligations, duties and risks associated therewith.

CUSTOMER SUPPORT

For any installation or service questions, please contact our BAKER technical department toll free: 1-877-640-2004.

BAKER DRIVETRAIN
9804 E. SAGINAW
HASLETT, MI. 48840

On the web:

www.bakerdrivetrain.com



BAKER Attitude Chain Adjuster Addendum

Attitude Chain Adjuster Upgrade Kit Note (PN 179-67K): The shoe (PN 176-67) will not be a slip fit onto the active plate (PN 175-67). You will need to press the shoe on as far as possible then draw the shoe in by tightening the keeper (PN 177-67) from the back of the active plate (PN 175-67) with the provided bolt (PN 25C175KCS).

If you are still having difficulty with installing the new shoe, then please give us a call at 517-339-3835 or Live Chat with our tech during business hours at www.bakerdrivetrain.com.